

SECTION A-A

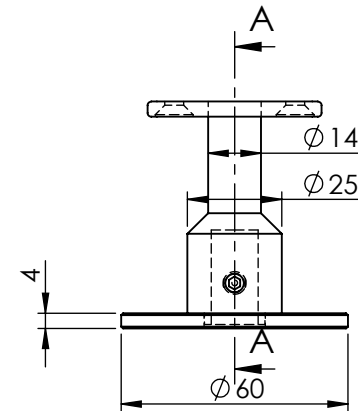
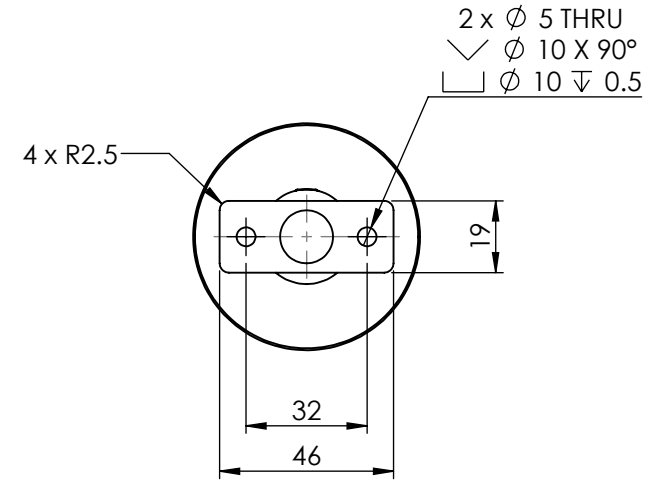

ITEM NO.	PART NUMBER	DESCRIPTION	QTY.
1	SSBASE-60	WASHER	1
2	SS4455-FT-2-60	BRACKET	1
3	SS-M6-6	SET SCREW-M6X6MM	1
4	LAG SCREW-8-60	LAG SCREW-8MMX60MM	1
5	SCS-5-25	SCREW-C/SUNK-5MMX25MM	2

DRAWN	B DOOLAN	18/06/2015
CHK'D	U WAUGE	18/06/2015
MATERIAL	304 STAINLESS STEEL	
FINISH	BRUSHED	
WEIGHT		

EMROWARE™
 www.emro.com.au

This drawing has been made with due care and attention however Emro do not accept any responsibility for variations. This drawing and information contained is the property of Emro and cannot be used without their consent.

CAT NO:	SS4455FT	REV: A
---------	----------	--------

DESCRIPTION:
 DELUXE CONCEALED STRAIGHT STAIR
 RAIL BRACKET-COMPLIES WITH
 CURRENT AS1428.1