

**WASHER OPTIONS**

SUPPLIED STD WITH 60MM ROUND

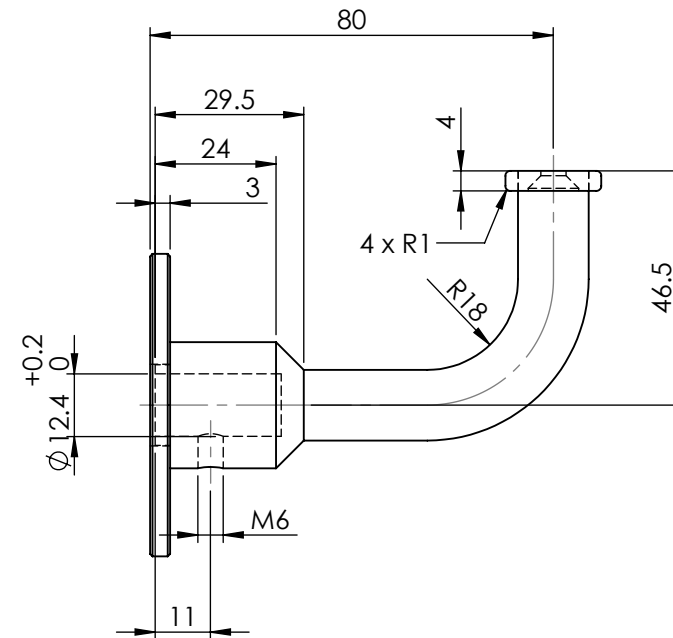
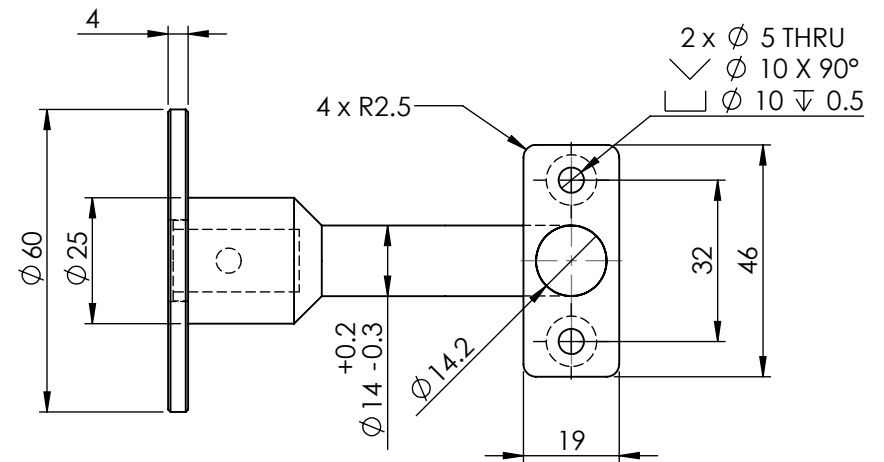
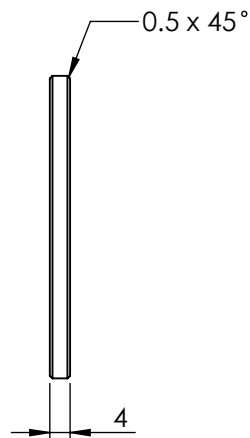
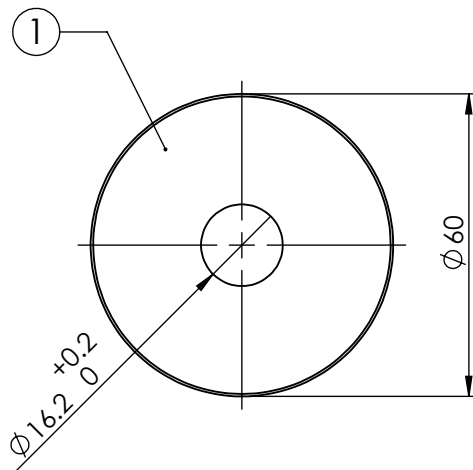
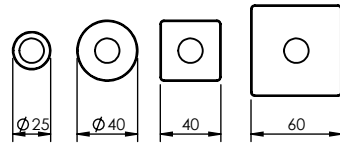

ITEM NO.	PART NUMBER	DESCRIPTION	QTY.
1	SSBASE-60	WASHER	1
2	SS441-FT-1	BRACKET	1
3	LAG SCREW-8-60	LAG SCREW-8MMX60MM	1
4	SCS-5-25	SCREW-C/SUNK-5MMX25MM	2
5	SS-M6-6	SET SCREW-M6X6MM	1

DRAWN	B DOOLAN	17/07/2015	CAT NO:	REV: A
CHK'D	U WAUGE	17/07/2015		
MATERIAL	304 STAINLESS STEEL			SS441FT
FINISH	BRUSHED			
WEIGHT				DESCRIPTION:
 <a href="http://www.emro.com.au">www.emro.com.au</a>				
<small>This drawing has been made with due care and attention however Emro do not accept any responsibility for variations. This drawing and information contained is the property of Emro and cannot be used without their consent.</small>				<b>DELUXE CONCEALED STAIR RAIL BRACKET-COMPLIES WITH AUSTRALIAN STANDARD AS1428.1-2009</b>